



Global Power Electronics Company

iMASTER U1

Powerful Micro Drive

AD Advanced Drive Technology
motor control & power conversion

www.adtech21.com

56 Beolmal-ro, Dongan-gu, Anyang-si, Gyeonggi-do, 14059, Korea
TEL : 82-31-459-5051 FAX : 82-31-459-5053



Specifications of the product are subject to change without notice for quality improvement.

Printed in Korea

AD Advanced Drive Technology
motor control & power conversion

Toughness & Easy to Use + General Purpose

Design Simple & Stylish appearance

Compact Minimize the space

Operation Easy Installation & Simple Operation



Applications
Suit for various machines

Supreme Performance

- User Friendly
- Built in PID function
- Traverse Operation

Powerful Torque

- V/F Control
- Sensorless Vector Control
- Powerful torque at low speed (150% @ 1Hz)

High Reliability

- Global Standard ; UL, CE, RoHS
- Conformal coating of internal PC board for harsh environment

Food. Mixer

Fan. Pump

Wood machine

Conveyor



■ Adoption of optimal algorithm to minimize the motor loss

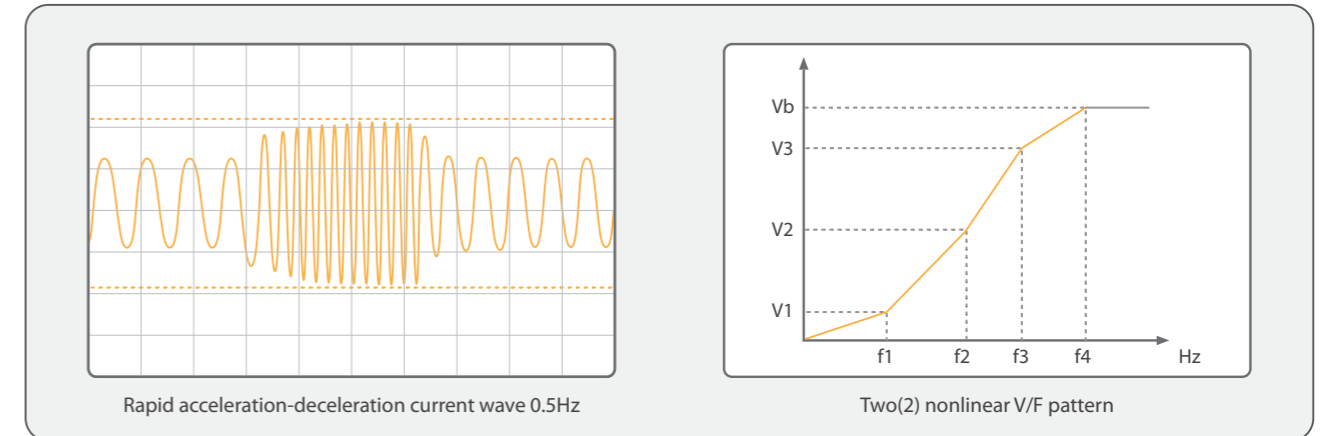

■ Standard RS-485 communication



■ Built in PID control

PID function is enable to temperature, flow or pressure control by proportional action(P), integral action(I) and derivative action(D) to reduce the difference between actual and target value.

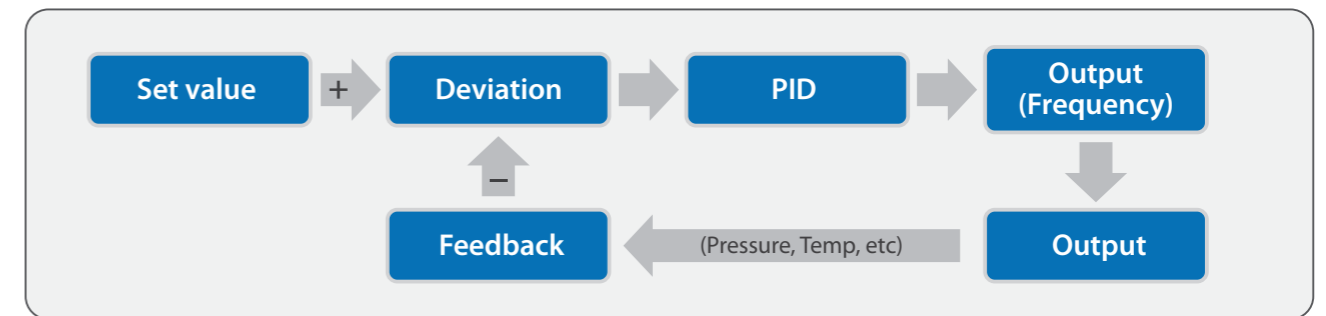

■ Various Functions

- Analog Input (0~10V, 4~20mA)
- Multi step operation (16 step)
- Jog operation

■ Global Standard



Product range

Motor Capacity (kW)	3 Phase 400V	1 Phase 200V
Standard Specification		
0.4	U1-0040-4	U1-0040-7
0.75	U1-0075-4	U1-0075-7
1.5	U1-0150-4	U1-0150-7
2.2	U1-0220-4	U1-0220-7
4.0	U1-0400-4	

Model Name

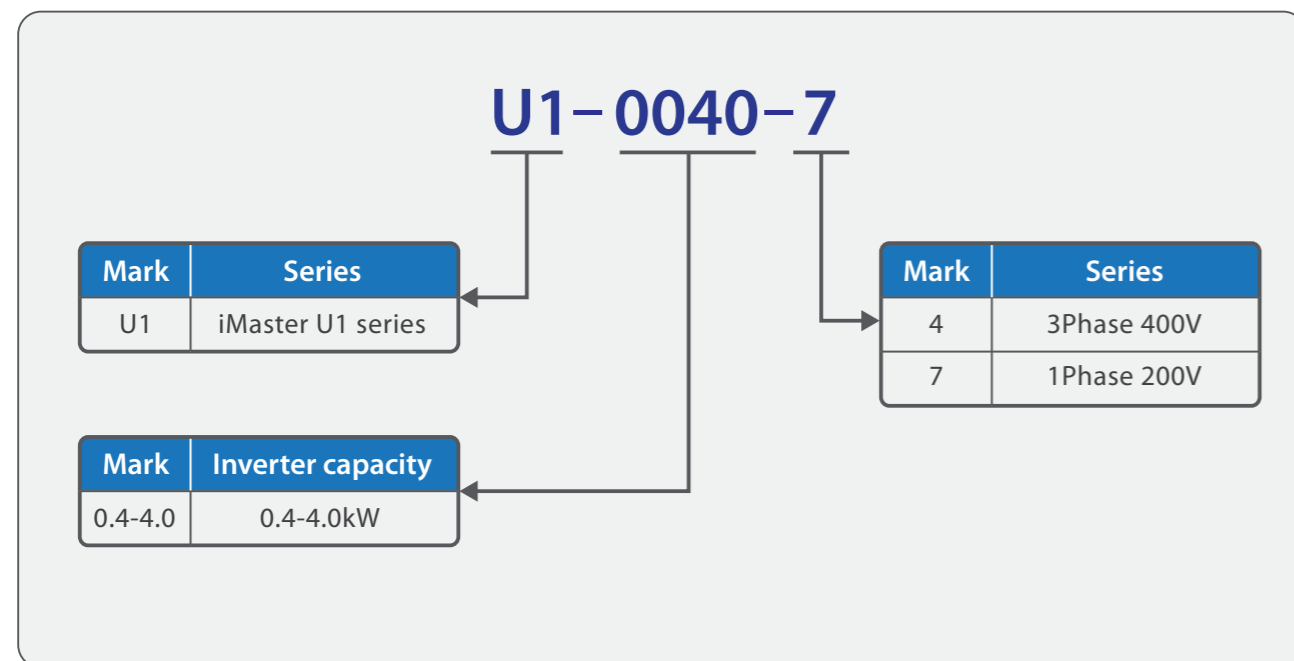

3 Phase 400V

Item	Specification					
Type (U1-□□□□-4)	U1-0040-4	U1-0075-4	U1-0150-4	U1-0220-4	U1-0400-4	
Applicable Motor [kW]	0.4	0.75	1.5	2.2	4.0	
Rated Output	Rated Voltage [V]	3 Phase 380V ~ 480V (with AVR function)				
	Rated Current [A]	1.8	2.5	4.3	6.3	10.5
	Overload Capacity	150% @ rated output frequency - 1 min. 200% @ rated output frequency - 0.5 sec.				
Rated Input	Rated Frequency (Fluctuation)	0.01~400Hz				
	Available Voltage [V]	3 Phase 380V (-15%) ~ 480V (+10%)				
	Frequency [Hz]	50/60Hz (Fluctuation : ±5%)				
	Input Current [A]	1.7	3.1	5.9	8.2	13
Braking Transistor	Built in					
Protection Degree	IP20 (IEC 60529)					
Cooling Method	Natural		Forced			
Weight (kg)	0.8	0.8	0.9	0.9	1.3	

1 Phase 200V

Item	Specification				
Type (U1-□□□□-7)	U1-0040-7	U1-0075-7	U1-0150-7	U1-0220-7	
Applicable Motor [kW]	0.4	0.75	1.5	2.2	
Rated Output	Rated Voltage [V]	3 Phase 200V ~ 240V (with AVR function)			
	Rated Current [A]	3.5	4.2	9.2	10
	Overload Capacity	150% @ rated output frequency - 1 min. 200% @ rated output frequency - 0.5 sec.			
Rated Input	Rated Frequency (Fluctuation)	50/60 Hz (Fluctuation 5%) 0.01 ~ 400Hz			
	Available Voltage [V]	1 Phase 200V (-10%) ~ 240V (+10%)			
	Frequency [Hz]	50/60Hz (Min. 47 ~ Max. 63Hz)			
	Input Current [A]	5.4	9.7	16.4	24
Braking Transistor	Built in				
Protection Degree	IP20 (IEC 60529)				
Cooling Method	Forced				
Weight (kg)	0.6	0.6	1.0	1.0	

■ Dimension

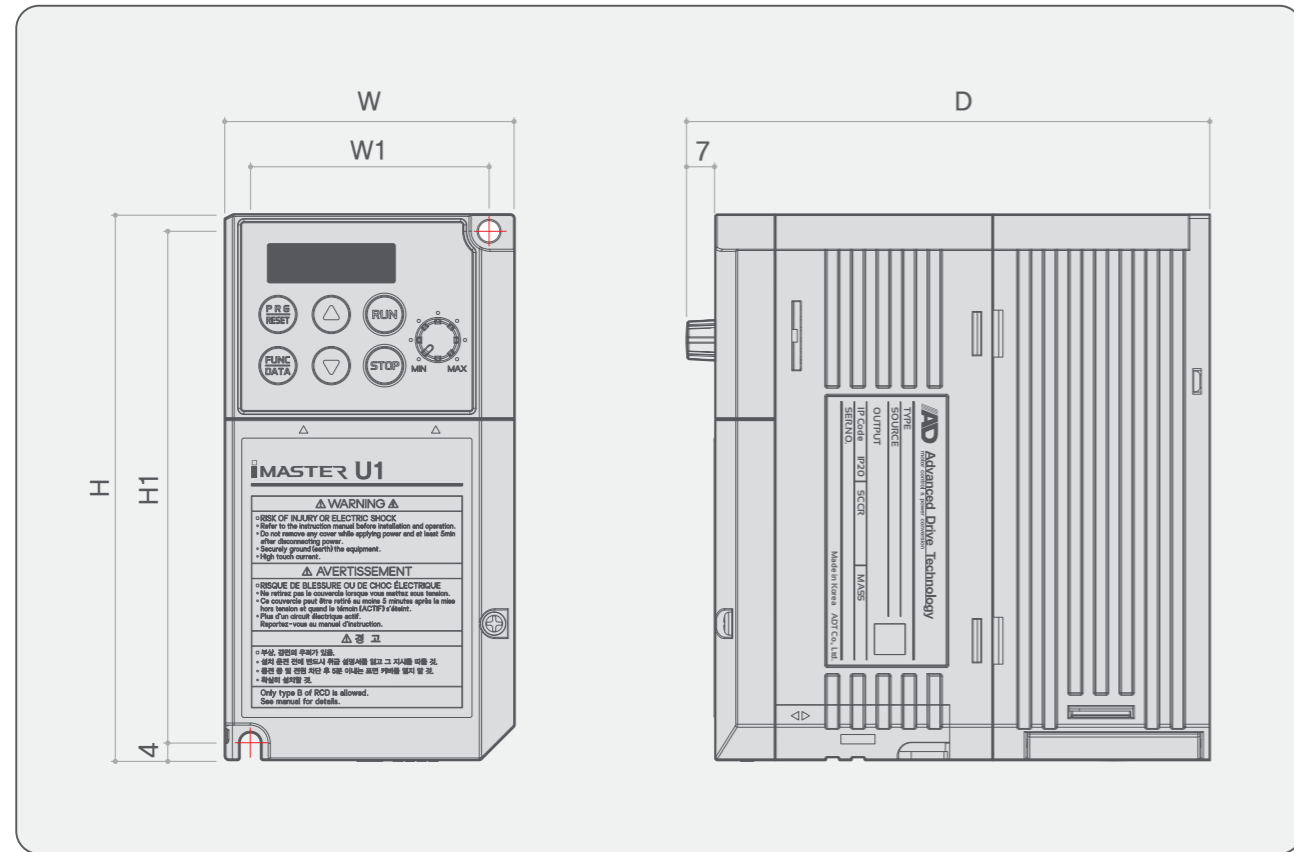

Applicable Motor [kW]	Model	Frame	W(mm)	W1(mm)	H(mm)	H1(mm)	D(mm)
3-Phase 400V	0.4	U1-0040-4	108	96	128	120	146
	0.75	U1-0075-4					
	1.5	U1-0150-4					
	2.2	U1-0220-4					
Single-Phase 200V	0.4	U1-0040-7	68	56	128	120	123
	0.75	U1-0075-7					
	1.5	U1-0150-7	108	96	128	120	146
	2.2	U1-0220-7					

■ Connection Diagram

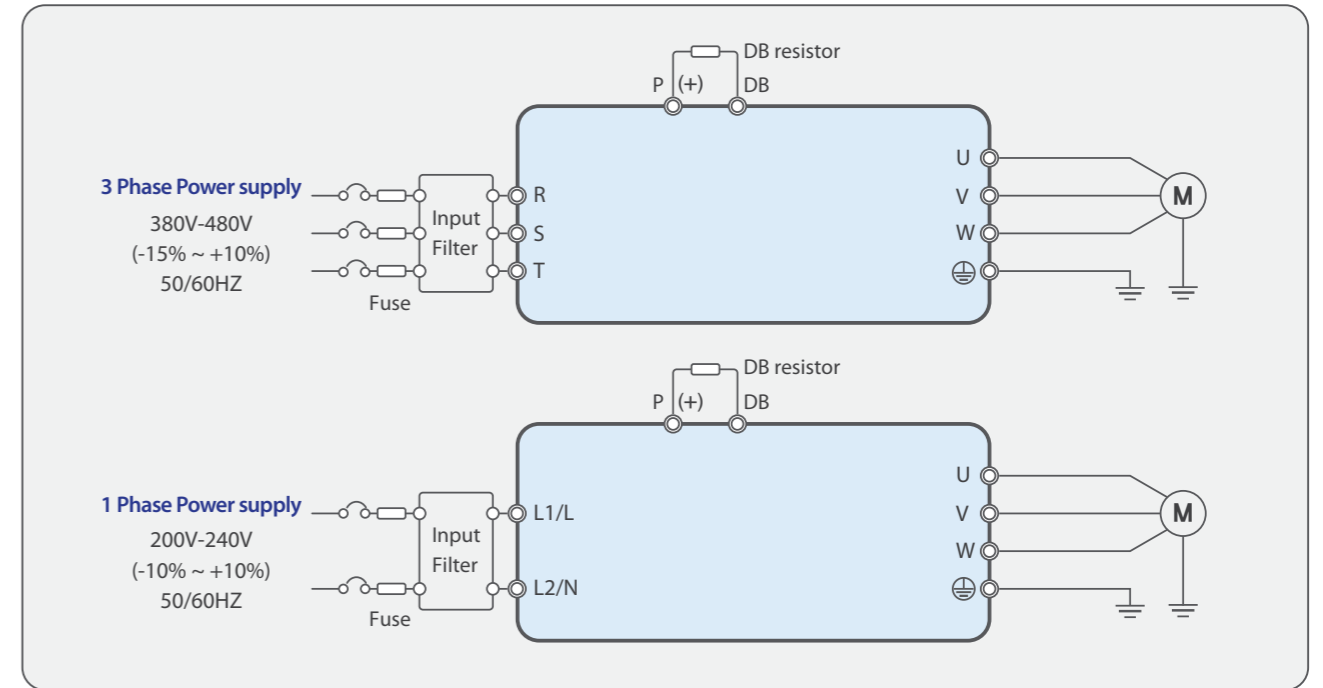

■ Wiring Diagram

